

# PRESENTATION

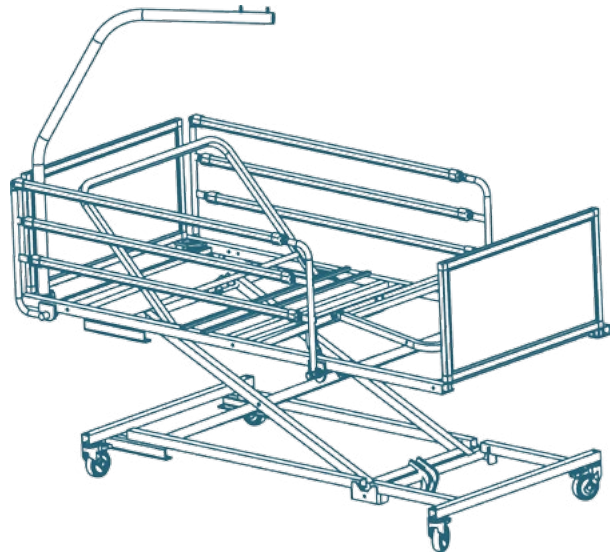

It is with great pride that NAUSICAA Medical proposes you a medical bed, the CONVERTISS 2/3 FUNCTIONS, for all patients and in accordance with European standards NF EN ISO 60601-2-52 and NF EN ISO 60601-1.

Our customers and partners often ask us what is our motivation to launch a new range of hospital beds?

How can we contribute uniquely to the bed market and distinguish our product from others?

The answer, as with all our products, rests in our ability to achieve a fusion of cutting-edge design, which goes beyond the standards of reliability, and innovative features.

Our uncompromising approach to the engineering of a product from concept to manufacturing, has allowed us to create a medical bed, designed for the patient and caregiver in order to manage risk effectively, while providing comfort and safety.

Its modern and “non-medical” design contributes to the sensation given to patients of being in a familiar environment rather than in a care facility, contributing positively to their recovery and improving their relationship to their bed rest.

During its conception process, our R&D department has taken into account all market's standards and rules while manufacturing its steel frame, implementing its multiple motorisation (2 or 3 motors) and developing its improved manoeuvrability.

Furthermore, it is compliant toward the new standard for medical bed performance and safety, NF EN ISO 60601-2-52, which focuses on many aspects including electrical safety, load bearing, stability and durability – and most notably on reducing risk of patient entrapment in and around the bed frame.

Our goal with the CONVERTISS 2/3 FUNCTIONS has always been to avoid any unnecessary complexity while achieving a high level of functionality.

