



BLUE WAYUP RANGE PRESENTATION



DESIGNED FOR ALL BUDGETS

Specially designed for the budget conscious without compromising on quality and attention to detail, the BLUE WAYUP range is a made in France entry-level line.

Thanks to its fast and efficient lifting movement during a transfer, it allows the patient to reach a standing position.

The devices contribute to the stimulation of the patient by activating the chest area and supporting the lack of muscle tone in the lower body along with a 150 kg weight capacity providing a safe transfer solutions for homecare.

The BLUE WAYUP range is declined in 2 different versions:
- Fixed base (page.26)
- Opening base legs: mechanical or electrical (page.27)



LITHIUM BATTERY

As an option, a lithium battery is available to enhance the use of the device.

NAUSICAA
Medical
BLUE WAYUP RANGE

SCAN
to watch



BLUE WAYUP

With Fixed Base

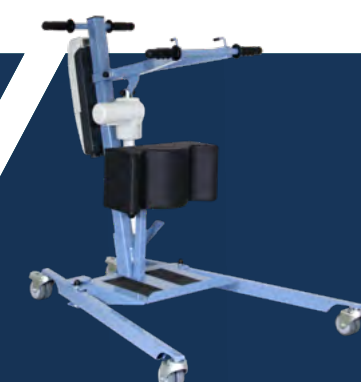

BLUE WAYUP

With Mechanical Opening Legs



BLUE WAYUP

With Electrical Opening Legs

BLUE WAYUP RANGE KEY FEATURES



A patented movement to stimulate the patient

With a 150 kg weight capacity on all products, the BLUE WAYUP range provides a safe transfer solution for homecare.

The devices support the lack of muscle tone in the lower body in order to contribute to the stimulation of the patient by activating the chest area.

All devices are equipped with all the features of a premium stand-up lift in order to safely transfer a patient from a bed, a comfort chair, a toilet seat or a wheelchair.

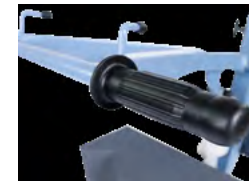
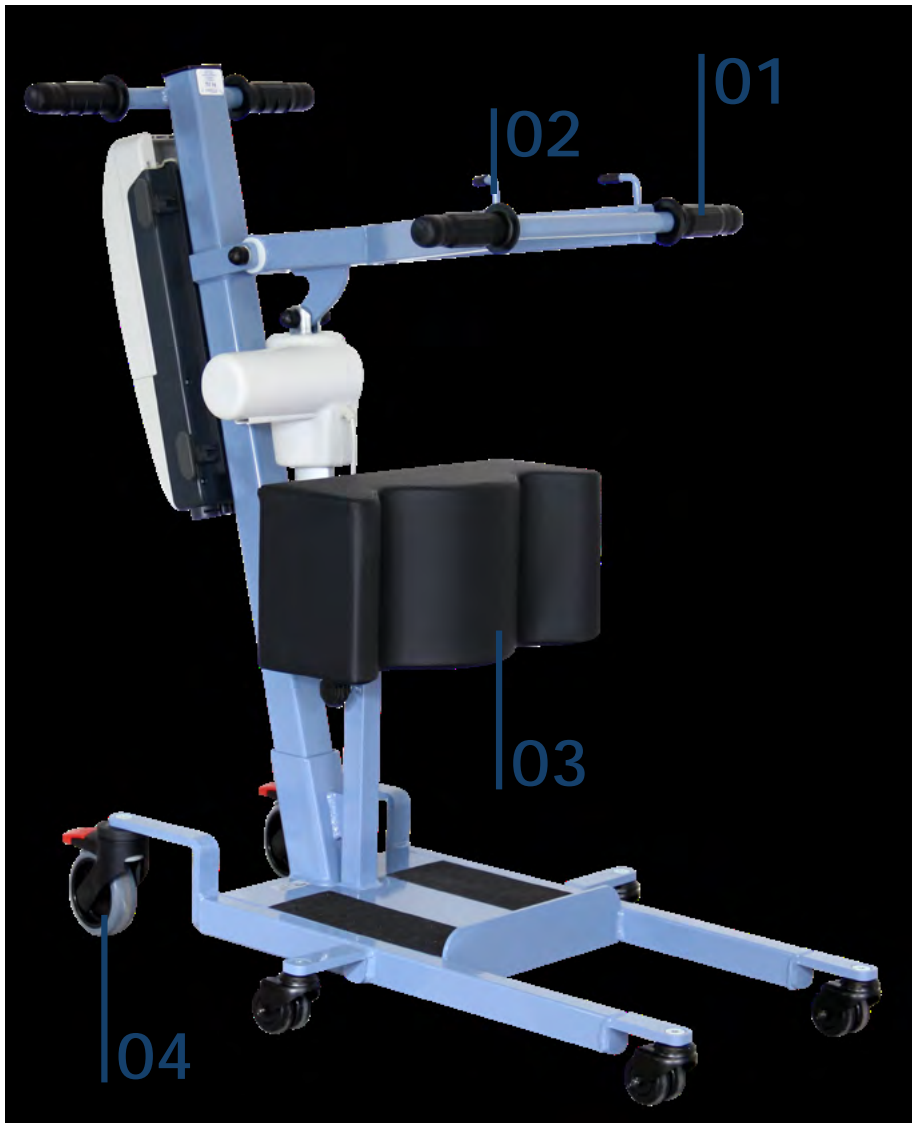

- 01** LIFTING ARM:
- 1 standard setting, ergonomic fixed handles for a tight grip



- 02** HANGING SYSTEM
- Hooks secured and curved in the opposite direction of the traction sling



- 03** FOAM SHINE BLOCK
- Comfortable and adjustable foam in height



- 04** CASTORS
- Double braked castors 75 & 100 mm
- Double wheels 75 & 50 mm