

BLUE FLYER PLUS with Electrical Opening Legs PRODUCT SHEET



Description :

- Frame made in steel
- Laser cutting and bending sheet metal, tubes and profiles
- Epoxy baked painting
- Ball bearing castors
- Total weight : 42 kg
- Weight capacity : 180 kg
- Lifespan : 8 years (except electrical parts)

- Medical products (93/42 EEC amended by 2007/47/EEC)
- Electromagnetic compatibility (2004/108/EC)
- Applicable standards :
 - BS EN 60601-1 : 2007
 - BS EN 60601-1-2 : 2007
 - BS EN ISO 10535 : 2007
- DC motor low voltage 24V
- 24V / 120VA power
- Lifting Actuator Maximum strength : 8000 N
- Opening base legs maximum strength : 3 000 N
- Lifting Stroke : 29 cm
- Electronic protection when overloaded
- Protection class : II
- Protection type : IPX 4
- Stop limit switch
- Box in ABS
- Handcontrol with spiral cable, low voltage 24V
- Protection against overloading through thermo-switch
- Loudness : less than 55dB at a distance of 1 meter.

Motorization Technicals Characteristics :

- Removable battery pack
- Digital display of the autonomy
- Power cord
- Emergency stop button
- Remote control 4 functions protection class IPX4
- Electrical security lowering system
- Wall charger (in option)

Dimensionals Characteristics :

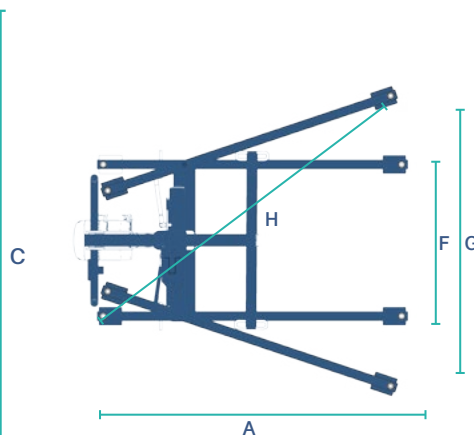
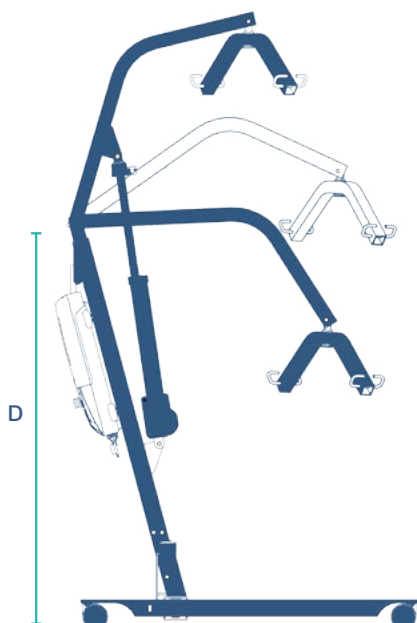

Dimensions (in mm)

- A. Total length: 1200 mm
- B. Minimum lifting height: 620 mm
- C. Maximum lifting height: 1800 mm
- D. Total height: 1350 mm
- E. Height of chassis: 113 mm
- F. Minimum base width: 650 mm
- G. Maximum base width: 1070 mm
- H. Turning diameter: 1380 mm