

FLYALU COMPACT PRODUCT SHEET



Description :

- Frame made in steel
- Laser cutting and bending sheet metal, tubes and profiles
- Epoxy baked painting
- Ball bearing castors
- Total weight : 35 kg
- Weight capacity : 200 kg
- Lifespan : 8 years (except electrical parts)

- Medical products (93/42 EEC amended by 2007/47/EEC)
- Electromagnetic compatibility (2004/108/EC)
- Applicable standards :
 - BS EN 60601-1 : 2007
 - BS EN 60601-1-2 : 2007
 - BS EN ISO 10535 : 2007
- DC motor low voltage 24V
- 24V / 120VA power
- Lifting Actuator maximum strength : 10 000 N
- Opening base legs maximum strength : 3000 N
- Lifting Stroke : 35 cm
- Electronic protection when overloaded
- Protection class : II
- Protection type : IPX 4
- Stop limit switch
- Box in ABS
- Handcontrol with spiral cable, low voltage 24V
- Protection against overloading through thermo-switch
- Loudness : less than 55dB at a distance of 1 meter.

Motorization Technicals Characteristics :

- Removable battery pack
- Digital display of the autonomy
- Power cord
- Emergency stop button
- Remote control 4 functions protection class IPX4
- Electrical security lowering system
- Wall charger (in option)

Dimensionals Characteristics :

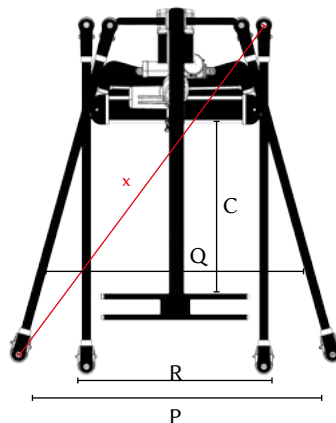
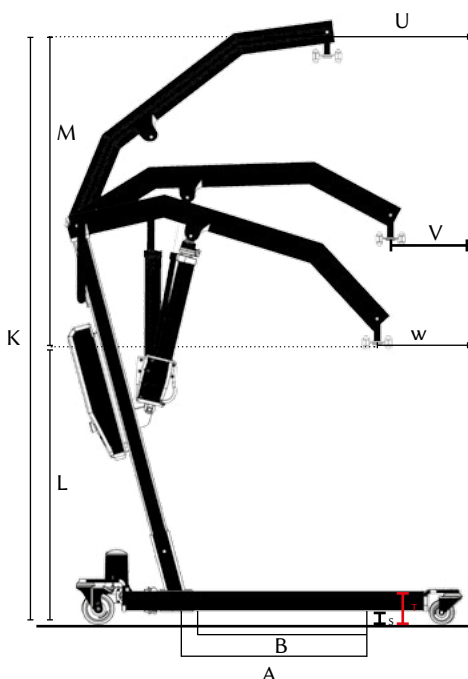

Dimensions (in cm)	
A	53
B	49
C	49
K	187
L	67
M	120
P	117
Q	96
R	65
S	5
T	13
U	77
V	38
W	53
X	133