

EASYLEV 2 with Mechanical Opening Legs PRODUCT SHEET



Description :

- Frame made in steel
- Laser cutting and bending sheet metal, tubes and profiles
- Epoxy baked painting
- Ball bearing castors
- Total weight : 41 kg
- Weight capacity : 150 kg
- Lifespan : 8 years (except electrical parts)

- Medical products (93/42 EEC amended by 2007/47/EEC)
- Electromagnetic compatibility (2004/108/EC)
- Applicable standards :
 - BS EN 60601-1 : 2007
 - BS EN 60601-1-2 : 2007
 - BS EN ISO 10535 : 2007
- DC motor low voltage 24V
- 24V / 120VA power
- Maximum strength : 3 000 N
- Lifting stroke : 49 cm
- Electronic protection when overloaded
- Protection class : II
- Protection type : IPX 4
- Stop limit switch
- Box in ABS
- Handcontrol with spiral cable, low voltage 24V
- Protection against overloading through thermo-switch
- Loudness : less than 55dB at a distance of 1 meter.

Motorization Technicals Characteristics :

- Removable battery pack
- Digital display of the autonomy
- Power cord
- Emergency stop button
- Remote control 2 functions protection class IPX4
- Electrical security lowering system
- Wall charger (in option)

Dimensionals Characteristics :

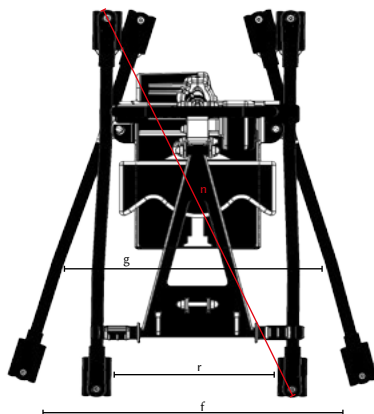
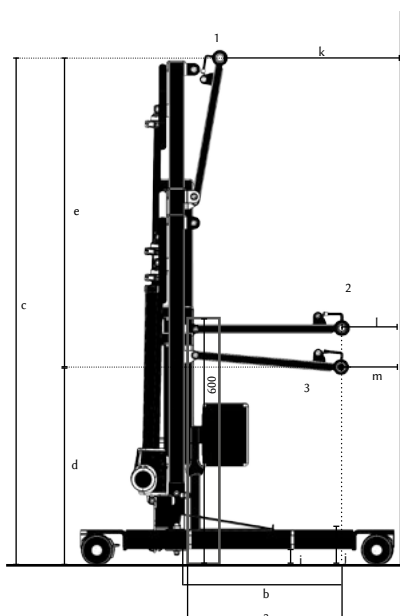

		Dimensions (in mm)
1	Highest Position	/
2	Maximal Reach Position	/
3	Minimal Reach Position	/
a	Maximal Reach at 600 mm	500
b	Maximal Reach at the Base	470
c	Maximal Height of the SCP	1620
d	Minimal Height of the SCP	690
e	Lifting Length	930
f	Maximal Internal Width	940
g	Internal Width at the Maximal Reach	770
h	Minimal internal Width	500
i	Minimal Distance from Floor	34
j	Base Height	110
k	Minimal Distance Between the Wall and the SCP at its Maximal Height	470
l	Minimal Distance Between the Wall and the SCP at its Maximal Reach	120
m	Minimal Distance Between the Wall and the SCP at its Maximal Height	130
n	Maximal Diameter	1110